

## Product Features

- Down-opened Panel is easy for fuse replacement.
- Automatic detection with multi-LED display for power out-of-phase, SCR over-heat, and fuse burn-down with one set of alarm dry contact output.
- Independent adjustment of Max and BIAS, easy adjustment for the VR of Max & SFS on the front panel.
- The auxiliary powers (AC1 & AC2) are independently controlled for all models.
- Build-in buffering output adjustment (SFS VR) with adjustable range 1~22 seconds. (Only for the phase control)
- In case of 0.5Hz sudden power losses, system output can be switched off immediately.
- Once the power is restored, the system will buffer the output to prevent the voltage surge for fuse burn-down.
- One main power design for 200~480VAC and automatic power frequency detection for 50~60Hz.
- In cases of SCR over-heat or fuse burn-down, the system output is stopped immediately. Once the malfunction is eliminated and power is restored, the system will buffer the output to prevent the fuse burn-down.
- Selectable signal 4~20mA, 1~5VDC, 2~10VDC, 0~20mA, 0~5VDC, 0~10VDC and dry contact points.
- Triggering circuit and the main board are designed separately to avoid the main board damage when main circuit malfunction.
- Safety top & bottom shielding covers are easy for wiring, using European detachable control signal connector for easy replacement without re-wiring installation.

## Control Mode & Output Wave

Control Mode	Output Wave		
	10% Output	50% Output	90% Output
Phase Angle Control			
Zero Crossing Control	 1 cycle ON & 9 cycles OFF	 1 cycle ON & 1 cycle OFF	 9 cycles ON & 1 cycle OFF

## Load Test

- **Phase angle control**: continuous phase angle control, steady output, current gauge reading remains steady. But, every half wave will produce harmonic wave.  
(Applicable loading): fixed resistance loading, variable resistance loading, inductive loading, IR light bulb.
- **Zero crossing control**: distributed zero crossing control, minimum resolution 1Hz, no harmonic wave, and current gauge reading oscillates. (Applicable loading): fixed resistance loading.

## LED lamp indication & trouble shooting

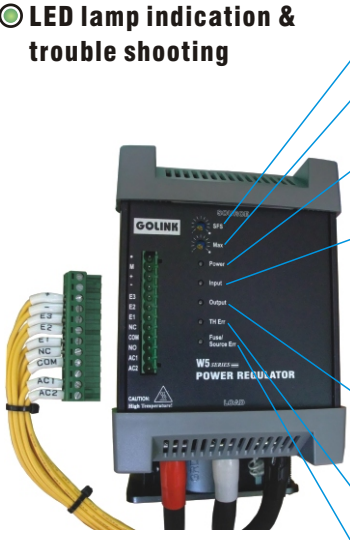

**SFS** Buffer rising time adjustment. (Clockwise adjustment will increase the time 1~22 seconds) No applicable for zero crossing type.

**Max** Maximum output voltage adjustment. (Adjusting range 0~100%, counter-clockwise adjustment will decrease the output. Set to zero will have no output.)

---

**Power: Auxiliary power on.**

- Off reason (1): Auxiliary power sources have no output --> make sure Ac1 & Ac2 have power output.
- Off reason (2): Control board may malfunction --> Please replace by new control board or call your supplier.

---

**Input: Control input signal is in.**

- Off reason (1): Control signal is not in --> Pls check the temperature gauge to see if there is input, check the connection and wiring.
- Off reason (2): Wrong connection on the electrodes of the control board --> Pls check the electrodes of the temperature Gauge.
- Off reason (3): Set to zero on the Max VR of the control board or outside VR --> Pls check two Vrs to see if any one of them is set to zero.
- Off reason (4): Control board malfunction --> Pls replace by new control board or call your supplier.

---

**Output: Power regulator is in output.** (Light or dark based on the output; but flash if for zero crossing control)

- Off reason (1): If the abnormal light "Fuse/Source Err" is ON. (Fuse burn down or main power has no output.
- Off reason (2): If the temperature light "TH Err" is on, the power regulator is over-heat.
- Off reason (3): If the input light is off. (No input signal)
- Off reason (4): If the input light is on. (Control board malfunction)

---

**TH Err: ON** (1) Power regulator is over heating --> cooling fan is not operating, check the power / fan damage, or if the fan is stuck by any object and get rid off it if necessary.  
**ON** (2) Bad ventilation or the ambient temperature is too high --> pls improve the ventilation.  
**OFF**: It's normal, the power regulator is not over-heating.

---

**Fuse/Source Err: ON** (1) Main power source have no output or out-of-phase --> Check the power output and all the abnormal conditions.  
**ON** (2) High-speed fuse burn down --> Pls replace the same spec. Fuse and check the shortage and the ground of the loading before restoring the power.  
**OFF**: It's normal.

## Selection of the input signal



Selection S1 Input signals 4~20mA, 0~20mA, MANUAL

Selection S2 Input signals 1~5VDC, 0~5VDC

Selection S3 Input signals 2~10VDC, 0~10VDC

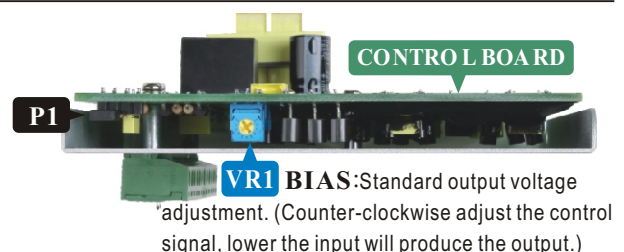

## Descriptions of the connectors

SP · SZ · TZ	TP · ZZ	Description	Notes
Connector No.	Connector No.		
FS		Detection of the fuse burn down	The connection from power to loading must be connected back to the FS side.
	•	Empty pin	Do not connect.
M	M	+5VDC	Only for this control board, not for other use positive control signal input.
+	+	Positive control signal input	The default setting is 4~20mA when the sticker is not marked.
-	-	Standard analog signal voltage	
E3	E3	Connected to the VR 3rd pin of the outside potentiometer	Adjustable output 0~100%, Please eliminate the shorted copper wire between E3 and E2 when using the outside potentiometer with VR. (2~10KΩ)
E2	E2	Connected to the VR 2nd pin of the outside potentiometer	
E1	E1	Connected to the VR 1st pin of the outside potentiometer	
NC	NC	Alarm connector output (normal close)	Connector capacity: 227VAC/2A 125VAC/2A 30VAC/2A
COM	COM	Alarm connector output (common point)	
NO	NO	Alarm connector output (normal open)	
AC1	AC1	Auxiliary power source	Please refer to the stick for the auxiliary power and voltage.
AC2	AC2		

## Order Information

Model No.	<b>W5</b>	<b>TP</b>	<b>4V</b>	<b>030</b>	<b>-</b>	<b>2</b>	<b>4</b>	<b>J</b>	← For example): Model No. <b>W5TP4V030-24J</b>
Control	SP	Single-phase angle control							
	SZ	Single-phase zero crossing control							
	TP	3-wire 3-phase angle control							
	TZ	2-wire 3-phase zero crossing control							
	ZZ	3-wire 3-phase zero crossing control							
Main power voltage	1V	110VAC (Only for single-phase power source)							
	4V	200~480VAC							
Normal rated current	030	30A							
	045	45A							
	060	60A							
	080	80A							
	100	100A							
	125	125A							
	150	150A							
	180	180A							
	230	230A							
	300	300A							
	380	380A							
	450	450A							
	580	580A							
	720	720A							
(Dash)	-								
Auxiliary power source code	1	1φ 110VAC							
	2	1φ 220VAC							
Input signal code	0	0~ 5VDC							
	1	1~ 5VDC							
	2	2~10VDC							
	3	0~10VDC							
	4	4~20mA							
	5	0~20mA							
	M	Manual adjustment							
*	Special								
Buffering time code	C	Buffering time 2 seconds						(Zero-crossing type product)	
	J	Adjustable buffering time, 1~22 seconds						(Phase-angle type product)	
Special code	(Blank)⇒	Standard type (Fixed resistance load, Inductive load or IR light bulb)							
	TF	Inductive reactance type loading							
	CL	Limited current type						(with additional charge)	
	CV	Fixed voltage type						(with additional charge)	



※ Note): W5-series has no included potentiometer (VR), the VR parts are option as following part numbers.

1) Part No. scale/0~100% : (sticker for scale range 0~100%)

2) Part No. KB-RN99D : (Knob)

3) Part No. VR-RV24YN-20S/B103 : (TOCOS potentiometer 24Ø 10KΩ)

## Wiring setup examples for single-phase, Single-phase zero crossing, and 2-wire 3-phase zero crossing

### Main circuit wiring diagram

- ※ When electromagnetic switch is used, please install it on the power source side.
- ※ For FS connector wiring, please refer to the right diagram.

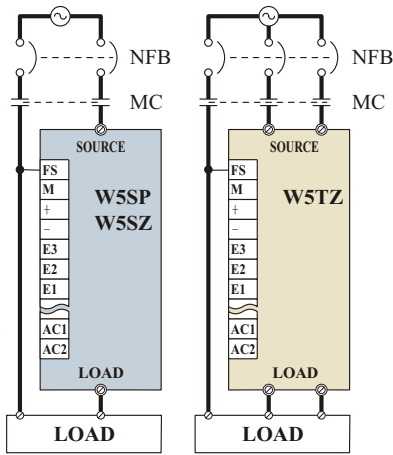

### 1) Control signal input

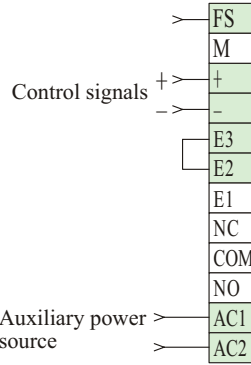

### 2) Manual control

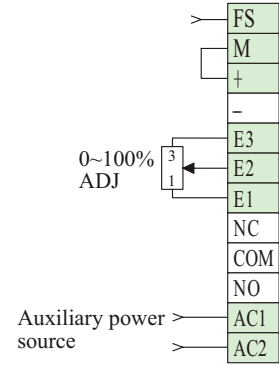

### 3) Limited adjustment for control signal input, output

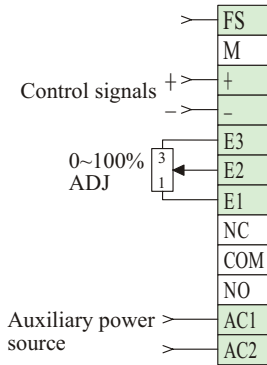

### 4) Dry contact signal input, external VR adjustment

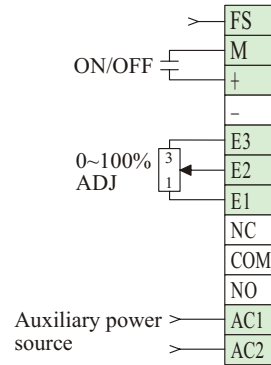

### 5) Manual-automatic relay switch, outside VR adjustment

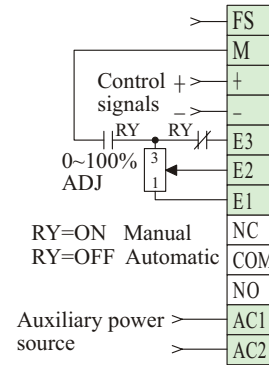

### 6) Manual-automatic relay switch

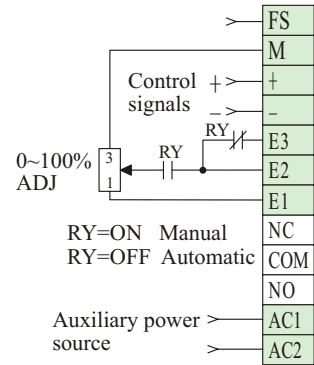

### 7) Control signal input, basic output setting

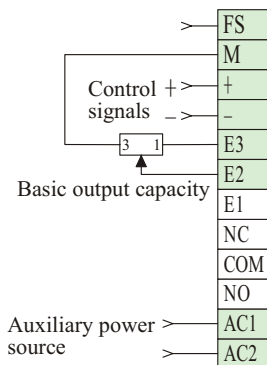

### 8) Multiple connection, only one for outside VR setting

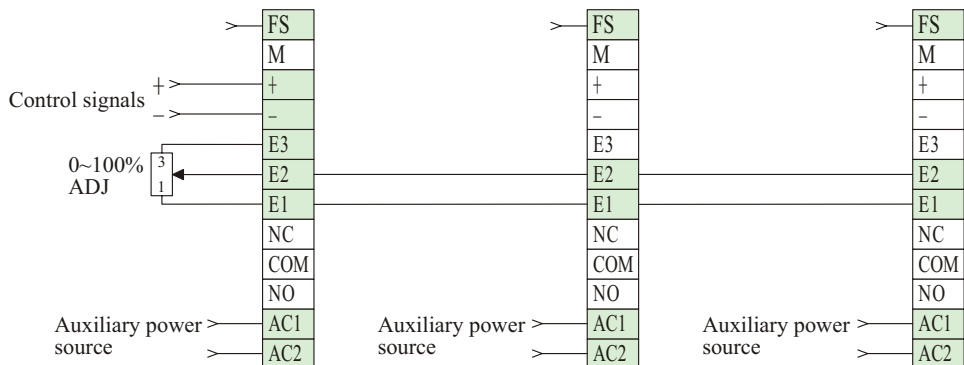

### 9) Basic and maximum output setting

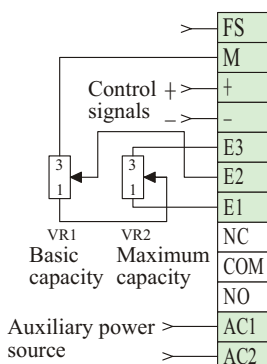

### 10) Connection for 3 units, independent external VR setting \*\*\* (limited for cascading max. 3 units) \*\*\*

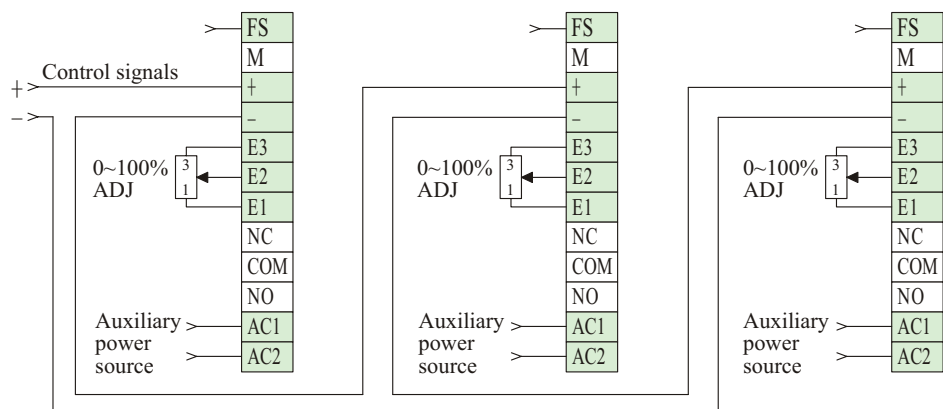

## Wiring setup examples for 3-wire 3-phase angle and 3-wire 3-phase zero crossing

■ Main circuit wiring diagram

※ When electromagnetic switch is used, please install it on the power source side.

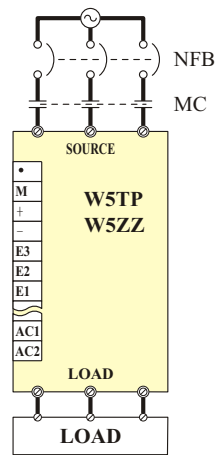

### 1) Control signal input

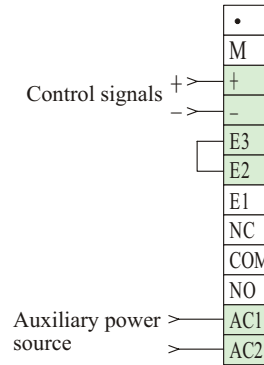

### 2) Manual control

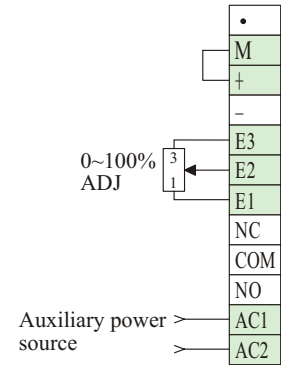

### 3) Limited adjustment for control signal input, output

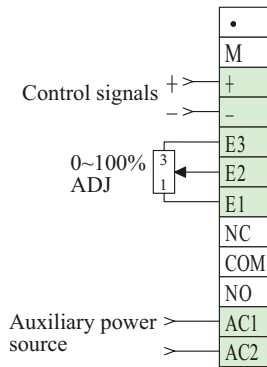

### 4) Dry contact signal input, external VR adjustment

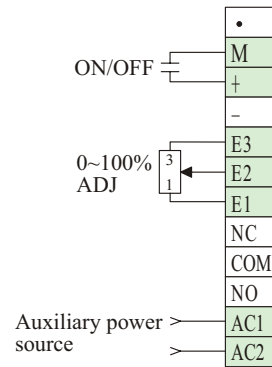

### 5) Manual-automatic relay switch, outside VR adjustment

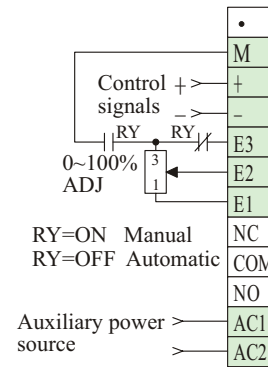

### 6) Manual-automatic relay switch

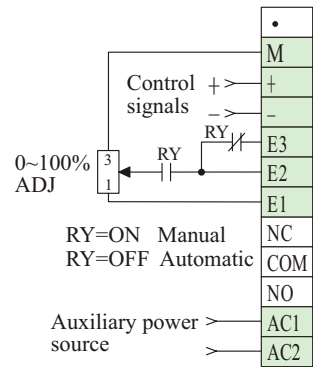

### 7) Control signal input, basic output setting

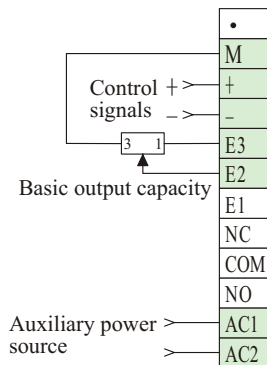

### 8) Multiple connection, only one for external VR setting

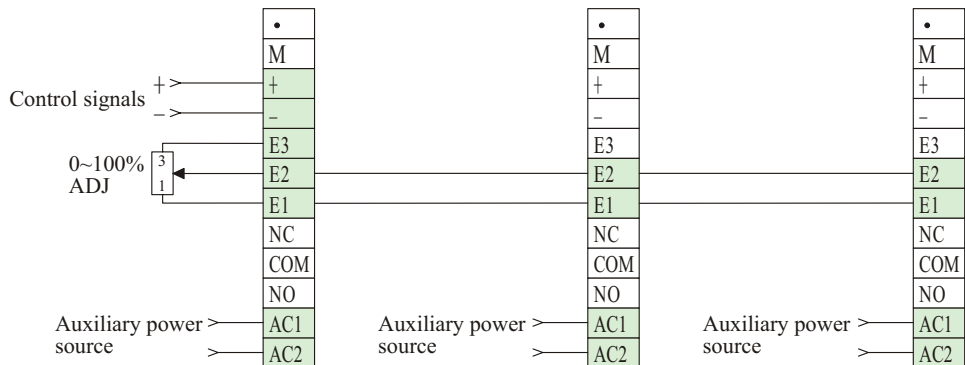

### 9) Basic and maximum output setting

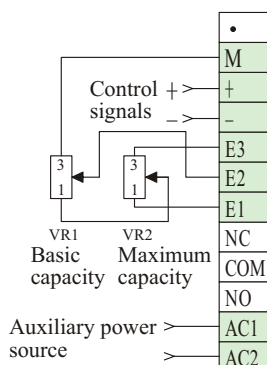

### 10) Connection for 3 units, independent external VR setting \*\*\* (limited for cascading max. 3 units) \*\*\*

